

OLIN ENGINEERING, INC

15622 COMPUTER LN HUNTINGTON BEACH, CA 92649 PH 714 897 1230 F 714 892 9268

WWW.OLINPUMP.COM DAVEOLIN@DSLEXTREME.COM



OWNERS MANUAL

MODELS

**5 40/5 45/5 50
5 65/5 85/5 110**



**GROUT – SHOTCRETE – CONCRETE – PRESSURE GROUTING
AND SPECIAL APPLICATION PUMPS**

OLINPUMP

BALL VALVE

OPERATIONS MANUAL

THIS MANUAL MUST BE READ AND FULLY
UNDERSTOOD BEFORE OPERATING THIS
EQUIPMENT.

Rev'd 9/10/2008

OLIN ENGINEERING, INC

15622 COMPUTER LN HUNTINGTON BEACH, CA 92649 PH 714 897 1230 F 714 892 9268

WWW.OLINPUMP.COM DAVEOLIN@DSLEXTREME.COM



**TOWING VEHICLE MUST
BE EQUIPPED WITH AND
PROPERLY CONNECTED TO
AN
ELECTRIC BRAKING SYSTEM**



**GROUT – SHOTCRETE – CONCRETE – PRESSURE GROUTING
AND SPECIAL APPLICATION PUMPS**

INTRODUCTION

OLINPUMPS are designed with the upmost attention toward dependability and easy maintenance. Close attention to the information and instructions in this manual will ensure a minimum of maintenance and maximum productivity and safety during operation.

Prior to pump start-up, the operator must thoroughly familiarize himself with the material contained herein in order that the pump be operated in a safe manner.

For safe operation of this equipment, the qualifications for, and the conduct of, the operator should be as follows:

ELIGIBILITY

1. The operator must have read and fully understand the “safety” manual provided by the manufacturer, and taken part in all “safety” training programs provided by his employer.
2. The operator must have taken part in the concrete pump operators training programs provided by “THE AMERICAN CONCRETE PUMPING ASSOCIATION” and have received a certificate of completion.
3. Equipment should be operated only by experienced operators, or a trainee under the direct supervision of an experienced operator, and no unauthorized person should be permitted to assist or remain in the immediate vicinity of the equipment while it is in operation or during the performance of any maintenance, inspection, cleaning, repair or make-ready operation.
4. Equipment should not be operated by individuals who cannot read and understand the signs, notices and operating instructions that are part of the equipment (in the language in which printed).
5. Equipment should not be operated by anyone under the age of 18 years.
6. Equipment should not be operated by anyone with seriously defective eyesight or hearing, and physical or mental impairment (such as epilepsy, heart disease, or progressive neuro-muscular deterioration), and that this is verified by a physical examination at least annually.
7. Equipment should not be operated while the operator is eating, reading, or is more than six (6) feet in distance from the controls.
8. Equipment should not be operated by an operator who has asked to be relieved because he feels physically or mentally unfit.
9. Equipment should not be operated at any new site, or at the start of a new shift, until a visual inspection is made of the condition of the equipment and the concrete delivery system.

10. Equipment should have a sign-off sheet attached to the equipment where the operator can report any damage, defect, problems or accidents to the next shift operator and work supervisor.
11. The operator of the equipment must not be under the influence of alcohol or drugs when operating the equipment.
12. Remote cable and/or radio are provided for the use of the “hose man” only, the pump operator must be no more than six (6) feet from the pump during its operation.

BEFORE WORKING ON PUMP:

1. REMOVE KEYS TO ENSURE THAT THE PUMP CANNOT BE STARTED.
2. DISCONNECT BATTERY CABLE.

BALL VALVE MODELS ONLY

SAFETY PRECAUTIONS

Head, eye and ear protection *must* be worn at all times during operation.

Any personnel assigned to repair, troubleshoot, or operate the equipment must first be thoroughly familiar with the operation instruction manual. The operator's safety and the safety of others is, at all times, of the utmost importance. To work safely, the operator must understand the job he does.

During operation, repair, or troubleshooting, problems may arise that seem singular, but may be due to several causes. The information in the manual should assist in finding these causes. If more information is needed, please consult your local distributor or the factory.

1. Never place any body parts or other objects in the hopper of the pump while the engine is running.
2. Never work on any part of the pump or engine while the engine is running. The operator should take the time to stop the power system for his protection.
3. Hydraulic oil systems can be dangerous. The operator should know the circuit he is repairing
—it may have very high pressure and injury could occur. The operator should stop the entire pump, and engine, and allow sufficient time for the oil pressure to drop to zero. He should check the system pressure gauge(s). Caution must be used when opening the circuits or components. Pressurized oil can cause severe injury.
4. The operator should never open any part of the material delivery system without stopping the pump, releasing the pre-charge from the surge chamber, and opening the 'Delivery System Pressure Release Valve'. CAUTION: high pressure may still be present in the manifold.

Note: For optimum performance, attention should be given to the pump positioning. The tongue end of the pump should sit level, or slightly lower, during pumping operations.

Note: Before operating the pump, you will need to fit a nitrogen bottle* into the rack and connect the surge chamber hose. Nitrogen is used to pre-charge the SURGE CHAMBER. To add nitrogen to the SURGE CHAMBER, slowly open, then close the valve on top of the bottle and read the SURGE CHAMBER pressure on the gauge fitted to the line running to the SURGE CHAMBER. NEVER leave the valve open. To drain nitrogen from the SURGE CHAMBER, slowly open the “bleed-off” valve on the valve stem, and recheck the SURGE CHAMBER pressure.

SURGE CHAMBER pre-charge (i.e., the pressure showing on the gauge when the pump is not in operation) may require adjusting as hose length increases, concrete becomes drier, or pumping output changes. PRE-CHARGE MUST NEVER EXCEED 300 P.S.I. AVERAGE PRE-CHARGE IS 100-150 P.S.I.

DO NOT ADD NITROGEN TO THE “SURGE CHAMBER” WHEN IT IS NOT FITTED TO THE PUMP. ALWAYS BLEED ALL NITROGEN AND DISCONNECT THE HOSE FROM THE “SURGE CHAMBER” BEFORE REMOVING IT FROM THE PUMP.

*not supplied by OLIN

FOR USE WITH BALL VALVE MODELS ONLY

1. PRE START-UP

Choose the correct concrete delivery system for the type of mix that is to be pumped. Set up the concrete delivery system avoiding tight bends, sharp objects and extremely rough surfaces. Make sure all clamps are locked closed and safety pins are fitted. Put enough water or priming slurry (a mixture of water and bentonite clay, or sand and cement mortar) in the hopper. Make sure surge chamber contains adequate pre-charge (100 P.S.I. is a good starting point.)

2. START-UP

Start the engine and let run at low speed, until the engine has warmed up. Increase the engine speed to full governed RPM. Set the output volume to at least 50%. The Auto/Manual switch must be in “auto” position. Switch the PANEL/OFF/REMOTE switch to PANEL position before concrete enters the hopper. Once the desired slump has reached the delivery system end, adjust the volume setting to the desired output, and set the surge chamber pressure as required to smooth out the delivery system. If remote ON/OFF control is to be used, you may now switch the PANEL/OFF/REMOTE switch to REMOTE.

3. CLEARING BLOCKAGES

First, determine if the blockage is before the discharge balls or after them. Before, will show no pressure reading on the Surge Chamber gauge in excess of the pre-charge. If this is the case, shut down engine, release all pre-charge from the Surge Chamber. Open the Delivery System Pressure Release Valve, disconnect coupling and swing away Valve to access the interior of Discharge Manifold. Wash out completely until Balls are free to move about. If pump will still not cycle, shut down engine, open and swing away Discharge Manifold, and washout Intake Manifolds and Hopper until thoroughly clean. Reconnect the Manifold, Surge Chamber and Pressure Release Valve. Recharge the surge chamber, and continue pumping.

4. BLOCKAGE IN DELIVERY SYSTEM

If blockage is in the delivery system, release all pressure from the Surge Chamber. Open ‘Delivery System Pressure Release Valve’, making sure concrete exits out the bottom. Locate blockage and carefully open system to remove blockage. Never assume that all pressure has been released. Clear blockage and close system. Immediately return to the pump, re-charge the surge chamber, close ‘Pressure Release Valve’, and resume pumping.

CAUTION: Do not hammer, or use a chisel on the inside or outside of the surge chamber, as damage to chrome surface will result.

5. STANDING TIME

If pump is stopped and material left in delivery system, stroke the pump at least once on each cylinder occasionally so as not to allow material to set. Repeat as often as required. Mix material in hopper with shovel before stroking each time. **DO NOT ALLOW MATERIAL TO SIT IN THE PUMP OR DELIVERY SYSTEM FOR MORE THAN 10 MINUTES WITHOUT STROKING, OR AT ALL IF MATERIAL IS HOT.**

6. WASHOUT

Pump remaining material from hopper. Fill hopper with water and pump out system at a moderate speed. Pump at least two more hoppers full of water through the system at **MAXIMUM** pumping speed. Remove the reducer and discharge elbow and clean out any material remaining in the manifold.

7. CLEANING YOUR PUMP

At the end of each job, after washing out pump and system, remove 4" coupling between Discharge Manifold and Delivery System Pressure Release Valve. Swing Valve away to the side, and inspect the interiors of both the discharge manifold and Pressure Release Valve, for any 'build-up' of concrete fines. Clean as necessary to ensure proper operation on next job. **NOTE;** Pressure Release Valve **MUST** occasionally(at least every 2-3 weeks) be disassembled, cleaned, and re-lubricated with grease to ensure proper, smooth operation. When re-assembling, be sure to tighten 'stem bolt' and nut adequately to ensure full closure of Valve, but still have relatively easy rotation/movement of handle.

At the end of each day clean your pump thoroughly, checking for leaks and noting its general condition. **REPAIR OR REPLACE ALL WORN OR DAMAGED PARTS AT THIS TIME. DO NOT OPERATE THE PUMP WITH WORN, DAMAGED, OR UNSAFE PARTS.** At this time, also check engine oil level (water level on water cooled engines). Check oil level in piston box, oil should be half-way up the chrome rods. Any water entering the piston box will settle to the bottom after pump sits for at least 24 hours, drain this accumulated water weekly, before start-up on Monday morning. Add vegetable-based oil if necessary to the piston box. Water may also be used, although it is not recommended. Oil level in surge chamber should also be checked weekly. Release pressure, remove pipe bushing, and use a dipstick or suitable substitute. Be sure to work dipstick through "guide" portion of piston, in order to get an accurate reading. About 3" of oil should be present.

NOTE: Never use acid, hammer, or chipping gun near chrome material cylinders, surge chamber cylinder, or hydraulic cylinder rods. Severe damage may be incurred, causing downtime and repair expense.

FOR USE WITH BALL VALVE PUMPS ONLY

GENERAL MAINTENANCE MODELS 5 40, 5 45 ,5 65, 5 85

1. REPLACING BALLS AND SEATS

A. Intake

Remove hopper screen.

Remove the six(6) hopper hold down bolts from hopper base.

Swing hopper to the side and remove seats and balls.

Clean all surfaces with a putty knife making sure they are free from slurry scale.

Remove any material build up from ball check area and inspect ball stop weldment for excessive wear.

Fit new balls, install new seats, making sure O' rings are in place.

Re-bolt hopper into place, and refit screen.

B. Discharge

Remove surge chamber.

Remove the six (6) discharge manifold hold down bolts.

Swing open the discharge manifold.

Remove the balls and seats, NOTING their position.

Inspect ball stop bolts for wear, replace if necessary.

Fit new balls and seats.

Rebolt manifold.

Clean surge chamber gasket groove, and mating face, and refit surge chamber.

2. REPLACING SURGE CHAMBER O' RING

Open air bleed valve and release air from surge chamber.

Remove air supply line and remove surge chamber.

Remove bushing in top of chamber and drain oil.

Remove the two (2) stop bolts from open end of the chamber and gently tap out the piston, using a suitable rod through the fill port in top of the chamber.

Clean O' ring groove and inside of the chamber thoroughly.

Fit new O' ring to piston and refit piston into chamber, after coating surface with oil or grease.

CAUTION: Do not damage O' ring when installing.

Refit stop bolts (use a non-permanent Loctite if desired) and refill the chamber with one (1) quart of hydraulic oil.- ***do not*** tighten bolts to a point of deforming the cylinder diameter.

3. REPLACING MATERIAL CYLINDERS SEALS (Poly Paks)

Remove piston box cover, and remove drain plug from bottom of piston box. Manually stroke one material piston, using the STROKE switch on the control panel, all the way towards the front of the pump. AUTO/MANUAL switch must first be switched to MANUAL.

Remove the four (4) Allen head bolts and remove the two (2) halves of the clamp. Take out the coupler and material piston. Remove the old poly paks, and clean the grooves in the piston. Fit new poly paks with the lips facing away from each other.

Refit the piston into the material cylinder using oil or grease to lubricate the poly paks and the inside of the material cylinder.

Before installing clamp halves, make sure all surfaces are clean of dirt and/or burrs which may prevent proper tightening.

Refit the clamp halves and tighten the four (4) bolts in a repetitive pattern to ensure tightness.

Replace the other side using the same method.

Refit drain plug, and refill the piston box, with clean oil until the level is half-way up the chrome rods.

Refit the piston box cover, tighten wing nut.

4. CHANGING THE HYDRAULIC OIL FILTER

Change at 50 hours on a new machine, then every 100 hours thereafter.

Remove the bolts on top of the filter housing and lift out the old filter element.

Fit new filter element and refit the lid.

CAUTION: Make sure O' ring is in place, do not over tighten the bolts.

5. ENGINE SERVICE

Follow the service program supplied by the engine manufacturer.

PERIODIC MAINTENANCE

After the first 250 hours, and every 500 hours thereafter, it is recommended that the hydraulic oil be changed.

NOTE: Trailer wiring color code (if fitted).

Brown.....Ground

Blue.....Electric brakes

Red.....Tail lights

Yellow.....Left turn and stop light

Green.....Right turn and stop light

ELECTRICAL TROUBLESHOOTING FOR BALL VALVE MODELS

SPECIAL NOTE: Disconnect stroke counter, and radio remote (if installed) before carrying out the following checks.

PROBLEM: Pump will not cycle.

1. Check all wire connections.
2. Check the fuse located on the Pump Control Board, hereafter referred to as the PCB.

USE A TEST LIGHT FOR THE FOLLOWING STEPS

3. If the fuse is “OK”, with the engine ignition switch turned ON, (you do not have to have the engine running) check that power is being supplied to terminal # 10 on the PCB connector strip. If there is NO power, then you may have to replace the ignition switch, however to get the pump cycling you can “hot wire” from the positive terminal of the battery to terminal # 10 on the PCB connector strip.
4. Check for power at center terminal of the ON/OFF/REMOTE switch, if none, replace the PCB.
5. Check for power at bottom terminal of the ON/OFF/REMOTE switch, if none, then replace the switch.
6. Check for power at center terminal of the AUTO/MANUAL switch, if none, then replace the PCB.
7. Check for power at top and bottom terminals of the AUTO/MANUAL switch, if none at either terminal, then replace the switch.
8. Check for power at the center terminal of the STROKE/STROKE switch, if none, then replace the PCB.
9. Check for power at the top and bottom terminals of the STROKE/STROKE switch, if none, then replace it.

If Pump cycles in MANUAL, but will not cycle in AUTO, go to the next section, if the pump still does not cycle at all, then proceed to step 6 in the following section.

PROBLEM: Pump will not cycle in auto.

1. Remove the “wash box” lid, hold it upside down.
2. With the ignition switch in the ON position, (you do not have to have the engine running) the ON/OFF/REMOTE switch in the ON position, AUTO/MANUAL switch in the AUTO position, check to see if the *green* lights are lit on both “shifting sensors”. If *green* lights are not lit, then check terminal # 7 on the PCB. If power is OK then replace the appropriate sensor cable. If both *green* lights are lit, then, using a metal object to test the shifting sensors, touch the metal object to the face of the shifting sensors one at a time, checking to see if the *yellow* light is lit on the shifting sensor *when* the metal object is touched to the face of the shifting sensor. If one or both lights fail to light, then replace the shifting sensor that does *not* light-up.
3. If the *yellow* light does *not* go out when the metal object is removed from the face of the shifting sensor face, then replace the sensor.
4. If lights are working correctly check to see if the relay (marked RH2LB on the PCB) is *latching* from side to side as the metal object is moved from the face of one sensor to the other. (Points are *making* and *breaking* contact). If not, then replace the cycling relay (marked RH2LB on the PCB board).
5. If relay is OK, then check for power at terminals # 2 and 3. If no power at either one, then replace the PCB.
6. Using a test light, check for power at the Directional valve coil wires (located inside the terminal box), on top of directional valve. If no power, then replace the cable from the PCB to the Directional valve. If OK, then check that the coils are being actuated when power is supplied to them. If a coil is *not* being actuated, then replace the D03 valve.

HYDRAULIC TROUBLESHOOTING FOR BALL VALVE MODELS

PROBLEM: Pump will not build hydraulic pressure.

1. Check the hydraulic oil level, add oil if necessary.
2. Start the engine and set R.P.M. to at least half throttle.
3. Set hydraulic pump output to at least 50%. And switch to “PANEL” and “AUTO”.
4. Using a small diameter tool, push in on the flush mounted detent pin located at the rear of dump valve stem. If pump cycles, replace coil. If not then....
5. Push in on the Directional valve (overrides on the D03 coil ends). If no pressure is developed, then push in on the opposite button. If still no pressure then.....
6. Remove the hydraulic pump and check the pump *drive* spline and pump input shaft. Replace as required. If pump drive and input shaft is OK then....
7. Have the hydraulic pump checked out by an Authorized service center.

OLIN ENGINEERING, INC.

PUMP MIX GUIDELINES

1. Uniform gradation of washed concrete sand and 1/2" minus aggregate along with sufficient cement content and water are important to successful pump operations. In some areas, the sand may be basically coarse and lacking in fines; the #50 - #100 - #200 screen sizes. If this is the condition (called gap grading), it is likely that jamming or blocking due to separation will occur in the manifold. It may be necessary to add blending sand - blow sand - mortar sand - fly ash - extra cement - or some other material to make up the deficiency of fines. SEPARATION AND BLOCKAGES are normally caused by POOR GRADATION.
2. A recommended pumpable mix design would be 70% sand and 30% aggregate, cement content to be a minimum of 6 sacks (564 lbs) per cubic yard. If IDEAL GRADATION OF MATERIALS exists, the above sand/rock ratios may be adjusted - less sand to more rock. Sand and cement mixes (without rock) can be pumped by increasing the cement content. i.e; some shotcreting applications, cellular foam concrete, cement slurries used for pressure grouting, tunnel liners and mud jacking.
3. Lab tests have proven that the above mix guidelines will produce compressive strengths of 3000 psi(28 day test), provided that excessive water is not used, and upwards of 5000 psi by increasing cement content.
4. In some areas where the gradation of sand and rock is ideal and sufficient cement is used along with admixtures, the OLIN ball valve concrete pump will handle up to a 50-50 ratio of sand and rock mixes.
5. When the mix is designed for "shotcrete" applications, it is normal to increase the cement (up to 7.5 or 8 sacks) and change the sand/rock ratio to 85% sand and 15% rock.
6. The OLIN ball valve concrete pump will pump efficiently when using cellular foam concrete mixes upwards of 70 lb. per cubic foot wet density. (Below 70 lb. materials (roof decks), cavitation may occur.

pmg

OLIN PUMP

CONCRETE PLASTER FIREPROOFING PUMPS

All concretes don't pump equally well. In fact, some don't pump at all. But if the supplier gives special attention to control of the material properties and amounts of materials used in his concrete he can produce pumpable mixes. Pumpability is related to several other properties of fresh concrete.

PROPERTIES OF FRESH CONCRETE

Concrete contains cement, water, fine aggregate or sand and coarse aggregate, usually gravel or crushed stone. Admixtures such as air-entraining agents, fly ash or water-reducing agents may also be added. How the fresh concrete behaves depends on properties and proportions of the materials used. Some of the factors that affect pumpability are:

- Slump—The slump test measures the ability of a concrete to flow. Higher-slump concretes that are still cohesive flow more readily and are easier to pump. To get a higher slump more water can be put into the mix, less aggregate can be used or a water-reducing admixture can be added. Adding water, though, to increase slump will also decrease concrete strength if no additional cement is used.

NOTE: *When slump tests are to be made on a pumped concrete job and a maximum permissible slump is specified, the specifications should state where the slump test is to be run—at the pump hopper or at the end of the pumpline. Concrete can lose slump as it passes through the line, especially if the aggregates are absorptive. A concrete could have a 6-inch slump at the hopper but only a 3-inch slump after it is discharged from the line.*

- Trowelability—A concrete that is easy to finish will generally also be easier to pump. Trowelability or finishability is affected primarily by

PUMPING CONCRETE: Techniques and Applications

the amount of fine sand, cement and other fines such as fly ash in the mix. Up to a point, the more fines and the higher the mortar volume, the lower the line pressure will be if slump is held constant.

- Segregation—Segregation is separation of coarse aggregate from mortar or separation of cement paste from aggregate in freshly mixed concrete. Mixes that segregate easily will be harder to pump.
- Harshness—Harsh concrete mixtures don't have enough mortar or aggregate fines and because of this they lack cohesion. They are more likely to segregate, aren't as trowelable and are more difficult to pump than mixes that have enough mortar. The slump test can be

Figure 2-1. If a part of the concrete used in a slump test shears off or falls away, the concrete is probably not pumpable.

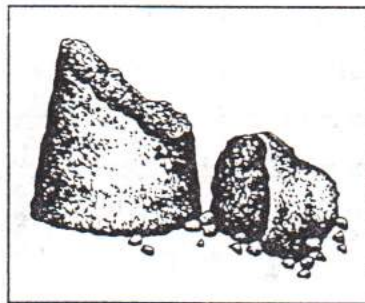

helpful in detecting harsh mixes. If the slumped concrete breaks off (Figure 2-1) or falls apart when lightly tapped with the tamping rod (Figure 2-2), the mix lacks cohesion and probably won't be pumpable.

Figure 2-2. Tap the side of a slump specimen with the tamping rod. A harsh mix (top drawing) will crumble. A mix with adequate cohesion (bottom drawing) will hold together.

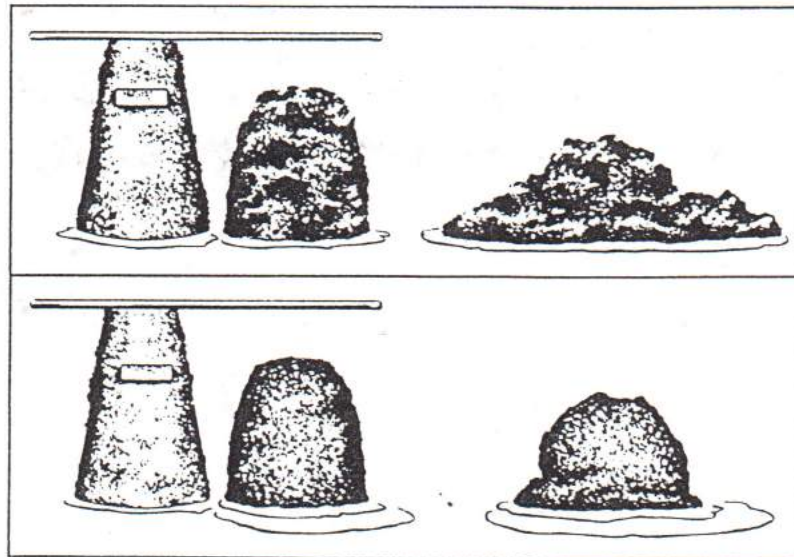

- Bleeding—Bleeding is movement of water to the top surface of concrete as heavier materials settle. Mixes that bleed excessively are difficult to pump. Even on jobs where the concrete isn't pumped the use of these mixes should be avoided because finishing will be delayed, flatwork surfaces will be less durable, secondary flooring such as tile may not adhere properly, and sand streaking will occur on vertical surfaces.

WHAT MAKES CONCRETE PUMPABLE?

Pumpable concrete can be pushed under pressure through a pipeline system that may include flexible hose as well as smooth steel line. In a pipeline, concrete moves in the form of a cylinder or slug separated from the pipe wall by a lubricating layer of water, cement and fine sand particles. The concrete slug must be able to pass through tapered sections (reducers) between the pump discharge port and the pipeline, slide along pipe walls and go around bends in the line. Cohesive mixes will deform as they go through bends or reducers. If the mix is harsh and doesn't deform readily, too much friction may develop between the concrete and the pipe walls and create a blockage or rock jam.

When concrete is pumped, water in the mix transmits the pump pressure to the cement and aggregates. But if spaces between aggregates are too large or the cement-water paste is too thin and runny,

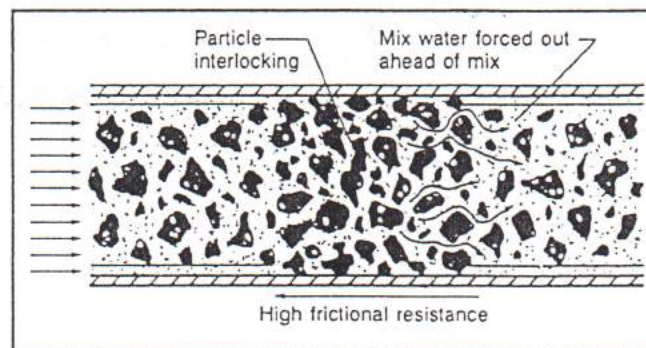

Figure 2-3. If pump pressure forces water out ahead of the mix a rock jam occurs. Friction between the aggregate and the pipe wall increases and the concrete stops moving.

DRAWING: AMERICAN CONCRETE INSTITUTE

PUMPING CONCRETE: Techniques and Applications

pump pressures cause segregation, forcing water out ahead of the mix. When this happens the lubricating layer is lost, coarse particles interlock, friction between the particles and the pipe wall increases and the concrete stops moving in the line (Figure 2-3). To keep this from happening, spaces between aggregate particles in the concrete must be made smaller so that the pressure at which segregation occurs is greater than the pressure needed to pump the concrete. Voids or spaces between aggregate particles are reduced in size by using a range of particle sizes from coarse to fine and by putting enough cement or other fines in the mix.

Concrete mixes that have *too many* fines may also be difficult to pump. Here, the problem isn't segregation. The mix is cohesive but friction between the concrete and the line may be so great that pump pressure isn't high enough to move the concrete. This type of pumping problem is more common with high strength concretes or with concretes containing a high proportion of very fine materials such as rock dust. These concretes are sticky and additional pressure is needed to overcome adhesion between the mortar and the pipe walls. Increasing the amount of well-graded coarse aggregate in these mixes will help to reduce the fines content and improve pumpability. Use of a coarser sand is also recommended.

EFFECT OF AGGREGATE ON PUMPABILITY

The important properties of coarse aggregates that affect pumpability are maximum size, shape and surface texture, and grading—the range of particle sizes present. If the porosity of the aggregate is exceptionally high, water absorption can also affect pumpability.

Maximum size of the coarse aggregate is considered when choosing line diameter. In a report entitled "Placing Concrete by Pumping

Methods" the American Concrete Institute (ACI) makes the following recommendations:

- The maximum size of angular coarse aggregate such as crushed stone should be limited to one-third of the smallest inside diameter of the hose or pipe.
- For well-rounded aggregate such as river run gravels the maximum size should be limited to 40 percent of the pipe or hose diameter.

Using these guidelines, a 4-inch-diameter line would be adequate for crushed stone concretes with up to 1-inch maximum size aggregate and gravel concretes with up to 1½-inch maximum size aggregate. Experienced pumpers have sometimes found that they get better results if maximum size for angular coarse aggregate doesn't exceed ¼ of the pipe diameter and maximum size for rounded coarse aggregate doesn't exceed ⅓ of the pipe diameter.

Shape and surface texture of coarse aggregate have an effect on mix proportions although concretes with angular or rounded and rough or smooth particles can be pumped satisfactorily. Concretes made with angular, rough particles usually have to have a higher sand content to be pumpable.

Grading of coarse aggregate used in concrete to be pumped can be the same as for concrete to be placed by other methods. Coarse aggregate grading requirements published by the American Society for Testing and Materials (ASTM) are shown in Table 2-1. With regard to pumping, grading of the combined coarse and fine aggregate is more important than grading of the coarse aggregate by itself.

Porosity of the coarse aggregate can affect pumpability if a significant amount of mix water is absorbed by the aggregate during

PUMPING CONCRETE: Techniques and Applications

pumping. When absorption causes problems, one solution is to thoroughly wet down the aggregate stockpiles before batching the concrete.

TABLE 2-1. GRADING REQUIREMENTS FOR
COARSE AGGREGATES (ASTM C 33)

	Size No. 467 1½ in. to No. 4	Size No. 57 1 in. to No. 4	Size No. 67 ¾ in. to No. 4	Size No. 7 ½ in. to No. 4
SIEVE SIZE	PERCENT PASSING			
2-in.	100	100	100	100
1½-in.	95 to 100	100	100	100
1-in.	—	95 to 100	100	100
¾-in.	35 to 70	—	90 to 100	100
½-in.	—	25 to 60	—	90 to 100
⅜-in.	10 to 30	—	20 to 55	40 to 70
No. 4	0 to 5	0 to 10	0 to 10	0 to 15
No. 8	—	0 to 5	0 to 5	0 to 5

Fine aggregate properties have a greater effect on pumpability than do coarse aggregate properties. Grading is most critical and of particular importance is the portion of the fine aggregate that passes a No. 50 sieve. Fine aggregate grading requirements given in ASTM C 33, Standard Specifications for Concrete Aggregates, are shown in Table 2-2. Tighter limits may be necessary when concrete is to be placed by pumping; ACI Committee 304 recommends that 15 to 30 percent of the sand pass the No. 50 sieve and that 5 to 10 percent pass the No. 100 sieve. Low-cement-content concretes made with coarser sands bleed more and are harder to pump. Adding more sand to these mixes won't help pumpability.

If available sands are deficient in the finer sizes they can be blended with selected finer sands or an admixture such as fly ash or stone dust can be added to make up the deficiency in fines.

Too many fines can also cause problems. Finer

materials have more surface area that has to be coated with the cement-water paste. So if there is too much fine sand or stone dust in a mix, more water will be needed to get the required slump. This extra water has several harmful effects:

- It reduces strength.
- It increases shrinkage.
- It makes concrete less watertight.
- It may cause dusting of floors.

As mentioned earlier, mixes with too much fine material may also develop excessive friction in the pipeline. For this reason, high strength concretes that have high cement contents may pump better when coarser sands are used.

LIGHTWEIGHT AGGREGATE CONCRETES FOR PUMPING

Lightweight aggregate concretes are frequently pumped. The lightweight aggregates usually absorb considerably more water than

TABLE 2-2. GRADING REQUIREMENTS FOR FINE AGGREGATES (ASTM C 33)

SIEVE SIZE	PERCENT PASSING
3/8-in.	100
No. 4	95 to 100
No. 8	80 to 100
No. 16	50 to 85
No. 30	25 to 60
No. 50	10 to 30
No. 100	2 to 10

PUMPING CONCRETE: Techniques and Applications

hardrock (normal weight) aggregates and under pressure in a pumpline this absorption is even greater. When line pressure forces mixing water into the aggregate pores, the resulting slump loss makes concrete pumping more difficult and sometimes impossible.

NOTE: Pumped lightweight aggregate concretes generally require the use of lower line pressures than are used for hardrock concretes. This minimizes slump loss. When bidding lightweight concrete pumping jobs, the contractor should remember that he usually won't be able to achieve as high a pumping rate in cubic yards per hour as he could with hardrock concrete.

Presoaking of the aggregate by sprinkling stockpiles for several days prior to batching will help to minimize absorption problems. A 48-hour minimum soaking period is recommended and longer periods are desirable. The stockpiles should be turned over frequently, using an end-loader, to make sure that wetting is uniform. To compensate for slump loss caused by absorption, it is usually also necessary to increase the slump of the concrete going into the pump.

Two very effective methods for presoaking aggregates are sometimes used at lightweight aggregate production plants. One uses a vacuum tank in which aggregate voids are filled with water. The other uses immersion of heated aggregate in water during the production process to fill the voids. Aggregates treated by either process reportedly respond to pumping in much the same way as normal-weight aggregates. Aggregates treated by either of these methods cost more than dry aggregates but are less likely to cause pumping problems. During cold weather, when sprinkling stockpiles may cause them to freeze, use of vacuum or thermally saturated aggregates is particularly advantageous.

On lightweight pumping jobs, a maximum permissible unit weight

may be specified. Before the job starts, the point at which unit weight tests will be run should be established. Water absorbed by the aggregates during pumping can increase the unit weight by as much as 2 pounds per cubic foot. Tests run at the pump hopper might indicate a unit weight of 115 pcf while tests at the end of the line could yield a unit weight of 117 pcf. To avoid disputes about compliance with specifications, the concrete producer needs to know in advance where the tests will be made.

ADMIXTURES FOR PUMPED CONCRETE

Admixtures are commonly used in most concrete, regardless of how the concrete is to be placed. However, many of the admixtures will affect pumpability as described below.

Air-entraining admixtures incorporate a large number of very small bubbles in the concrete. The main reason for putting entrained air in the mix is to improve resistance to deterioration caused by freezing and thawing. However, the air also increases pumpability because of improved plasticity, less bleeding and less segregation. Especially with crushed aggregates, too little air increases line friction and makes start-ups after pumping delays more difficult. About 3 to 5 percent air by volume of the concrete is the best amount for pumping purposes. Too much air can decrease pumping efficiency by absorbing some of the pump stroke energy as the air compresses.

Water-reducing admixtures can be used to increase slump without adding water. Or they can be used to reduce the amount of water needed to get a desired slump. High-range water reducers or superplasticizers can increase the slump of a concrete by as much as 6 inches without increasing the chance that segregation will occur. They have been used successfully on many pump jobs, especially for

PUMPING CONCRETE: Techniques and Applications

high-rise construction. However, water reducers will not by themselves make an unpumpable concrete pumpable.

Fly ash is a fine material which can be added to concrete either as an admixture or as a partial cement replacement. The additional fines reduce the void content of the solid materials and make the mix more pumpable. Because of their smooth surface and rounded shape, fly ash particles also reduce bleeding and internal friction without increasing the water required to keep the slump constant. Fly ash may make concrete set more slowly; this can delay finishing and increase the time period during which vertical forms must withstand maximum form pressures.

Pumping aids are admixtures with the sole function of improving pumpability. They do this by making the water in the concrete thicker or more viscous. This makes the water less likely to be forced out of the concrete under pressure.

Accelerators are added to concrete to make it set and gain strength faster. If accelerators are used in pumped concrete, delays are a problem to be avoided because the concrete may lose slump faster or even set up in the lines. Accelerators are **not** antifreeze agents. If pumping lines are exposed to freezing temperatures, the concrete will freeze regardless of whether an accelerator has been added to it. Calcium chloride is the most commonly used and the least expensive accelerator. However, many specifications prohibit the use of calcium chloride in concrete because it increases the chance that reinforcing steel will corrode.

Retarders make concrete set more slowly. They may help the pumping operation under hot weather conditions, when very long pipelines are used or when the placing rate is very slow.

MIX DESIGNS FOR PUMPABLE CONCRETE

Selection of concrete mix proportions is not usually the contractor's responsibility. There are several good sources of information for those interested in learning more about mix design and these are listed at the end of the chapter. There are also computer programs and portable hand-held computers available for use in selecting proportions for concrete that is to be pumped. Regardless of the mix design method used, trial mixes of concrete intended for pumping should first be prepared and tested in a laboratory. Tests and observations will indicate whether the slump, cohesiveness, finishability and strength are acceptable.

Even if it looks good in the laboratory, pumpability of the proposed mix for more complex projects should preferably be verified with a full-scale pumping test under field conditions. There's no worse place to find out that a mix won't pump than on a jobsite with fifteen laborers and finishers standing around waiting for the concrete.

Testing a concrete mix for pumpability involves duplicating anticipated job conditions. The batching and truck mixing should be the same, the same pump and operator should be present and the pumpline layout should be similar to ones that will be used on the actual job. Making the effort to do this is worth the time and money. A job-proved mix prevents a lot of headaches and problems, especially on the first few pours for a project.

EFFECT OF CHANGES IN MIX PROPORTIONS

Uniform concrete from batch to batch is essential to a smooth-running pump operation. If concrete properties change frequently during a pour the pumping characteristics are also likely to

PUMPING CONCRETE: Techniques and Applications

change. The pump operator must recognize changes in the mix that could affect pumpability. The following general observations about pump mixes may help the pump operator to make judgments about the effect of mix changes on pumpability.

- Enough mortar (sand plus cement plus water) is needed in the concrete to ensure good pumpability. If pumping has been progressing satisfactorily on a job and the mix changes to a rocky or harsh appearance, pumping problems may develop.
- A sufficient amount of fines (cement, fly ash, fine sand or stone dust) is needed to ensure good pumpability. Increased bleeding is one good indicator that there aren't enough fines in the concrete. Mixes that are already starting to bleed in the pump hopper aren't likely to pump well.
- A high enough slump is needed to ensure good pumpability. If the mix doesn't have enough water in it and is too stiff it may not feed properly into the pumping cylinder and will not be as pumpable. Adding water at the jobsite is usually permitted but care should be taken not to add too much. Water should be added in increments of one gallon per cubic yard until the correct slump is reached. The concrete must be thoroughly mixed after water is added.
- If the slump is too high, concrete pumpability may decrease. Although some concretes containing superplasticizers may pump well at slumps as high as 8 or 9 inches, concretes without admixtures at slumps greater than 6 inches are very likely to segregate in the pumpline and create rock jams.
- On lightweight pumping jobs, if the slump hasn't changed at the hopper but the labor foreman starts calling for more water,

absorption of water is probably the problem. Check with the plant to see if they're using aggregate from a dry part of the stockpile.

Periodic unit weight checks on the coarse aggregate by the concrete producer can help him to detect changes in aggregate moisture content. He can then make needed adjustments in mix proportions.

One of the operator's best tools for evaluating the concrete is his pump. The pump gauges and even the sound of the pump will indicate variations in pressure required to move each batch. Changes in material composition, aggregate gradings and mixing efficiency can all cause the variations; erratic changes in line pressure for a pump in good repair indicate quality control problems with the concrete.

EFFECT OF WEATHER EXTREMES

Hot and cold weather concreting using pumps presents some special problems. In hot weather, concrete sets faster. If delays are anticipated, slow or intermittent pumping is necessary even if it means wasting some concrete. A little wasted concrete is much preferable to risking a blockage that requires disassembling and cleaning to free the line. It's also very important to have tight joints in the pumpline so that no grout leaks out. Under extremely hot conditions it may be necessary to wrap the lines in wet burlap so that they are cooled by evaporation.

In cold weather the main danger is freezing of the concrete in exposed lines. Often this can be avoided by running the vertical line and as much of the horizontal line as possible inside the heated enclosure where concrete is being placed. Line exposed to the cold can be wrapped with insulation to retain heat and reduce the effect of wind chill. Remember that accelerators won't prevent concrete from freezing in the lines.

OLIN ENGINEERING, INC

15622 COMPUTER LN HUNTINGTON BEACH, CA 92649 PH 714 897 1230 F 714 892 9268

WWW.OLINPUMP.COM DAVEOLIN@DSLEXTREME.COM



MILLENNIUM SERIES 3

PARTS LIST

MODELS

**5 40/5 45/5 50/5 65
5 85/5 110**

**ALWAYS SPECIFY MODEL, DATE OF
MANUFACTURE, & PRODUCT I D No
WHEN ORDERING PARTS**



**GROUT – SHOTCRETE – CONCRETE – PRESSURE GROUTING
AND SPECIAL APPLICATION PUMPS**

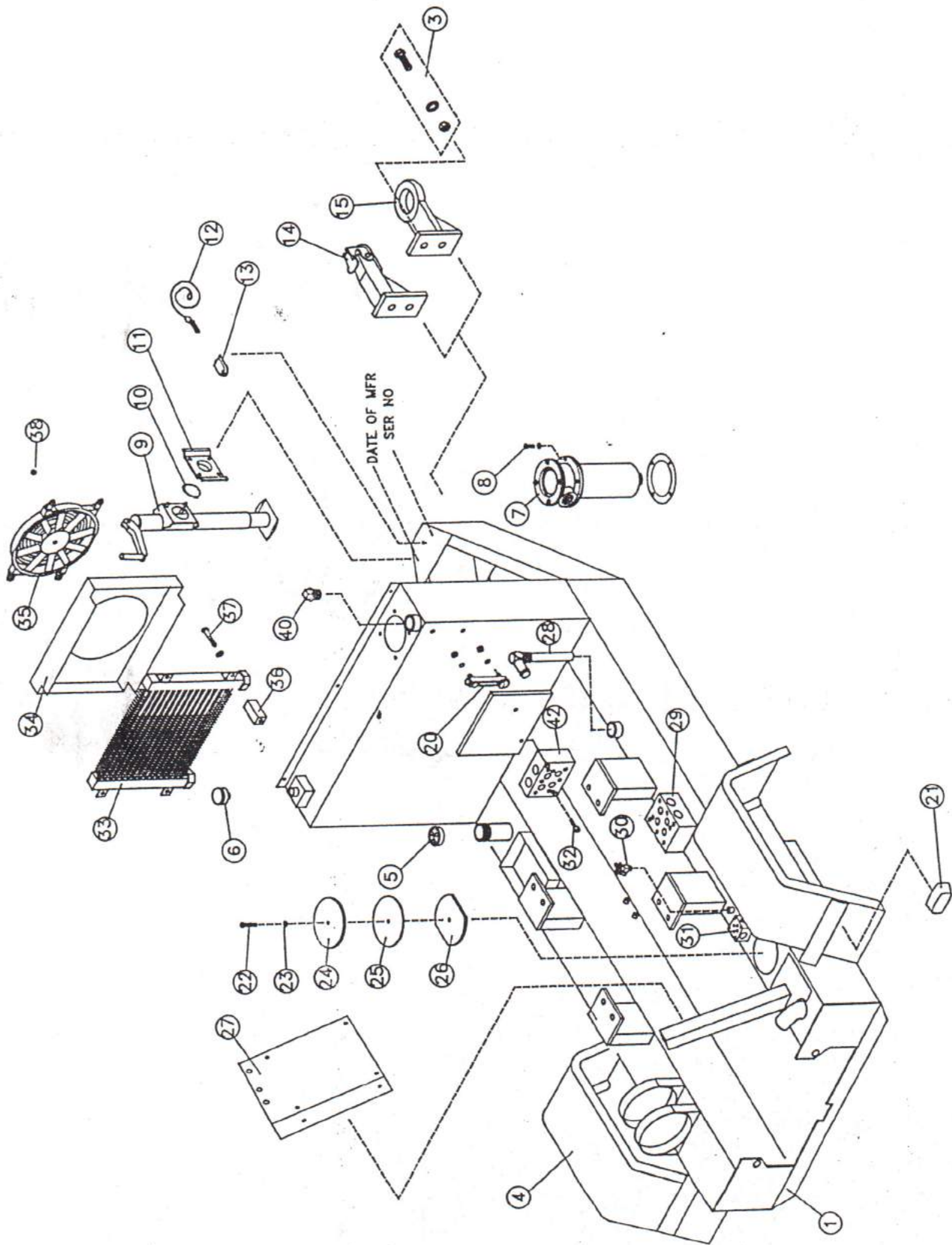

PARTS LIST: MODELS 5 40/5 45/5 65/5 85

GROUP 1

ITEM #	PART #	DESCRIPTION	# REQ	FOR MODEL (S)
1	02012	FRAME	1	5 40/5 45/5 65
	02013	FRAME	1	5 85
3	02285	HITCH BOLT & WASHER	2	ALL MODELS
4	02060	FENDER (NON OPERATORS SIDE)	1	5 40/5 45/5 65
	02060-0	FENDER (OPERATORS SIDE)	1	5 40/5 45/5 65
	02061	FENDER (NON OPERATORS SIDE)	1	5 85
	02061-0	FENDER (OPERATORS SIDE)	1	5 85
5	02081	FUEL CAP	1	ALL MODELS
6	02100	OIL PRESSURE BREATHER	1	ALL MODELS
7	02120	HYDRAULIC OIL FILTER ASSEMBLY	1	ALL MODELS
	02140	HYDRAULIC OIL FILTER ELEMENT	1	ALL MODELS
8	02160	BOLT & WASHER	4	ALL MODELS
9	02180	JACK STAND	1	ALL MODELS
10	02200	SNAP RING	1	ALL MODELS
11	02220	STAND BRACKET	1	ALL MODELS
12	02240	BREAKAWAY CABLE	1	ALL MODELS
13	02260	BREAKAWAY SWITCH	1	ALL MODELS
14				
	02281	COUPLER, 2 5/16" BALL TYPE	1	AS REQUIRED
15	02300	COUPLER, PIN TLE TYPE	1	AS REQUIRED
20	02320	LEVEL/TEMP GAUGE	1	ALL MODELS
21	02340	LIGHT ASSEMBLY	2	ALL MODELS
22	02455	BOLT	1	ALL MODELS
23	02456	SEALING WASHER	1	ALL MODELS
24	02457	TOP PLATE	1	ALL MODELS
25	02458	GASKET	1	ALL MODELS
26	02459	BOTTOM PLATE	1	ALL MODELS
	02460	MAGNET	1	ALL MODELS
27	02449	CONTROL PANEL MOUNTING BRACKET	1	ALL MODELS
30	10420	BLEED VALVE	1	ALL MODELS
32	10020	BOLT & WASHER	2	ALL MODELS
33	10600	OIL COOLER & FAN HOUSING	1	WHEN INSTALLED
35	10610	FAN	1	WHEN INSTALLED
36	10612	SPACER	4	WHEN INSTALLED
37	10613	BOLT & WASHER	4	WHEN INSTALLED
38	10620	NUT, LOCKING	4	WHEN INSTALLED
40	02465	OIL FILLER PLUG	1	ALL MODELS
42	10021	SUB PLATE	1	ALL MODELS

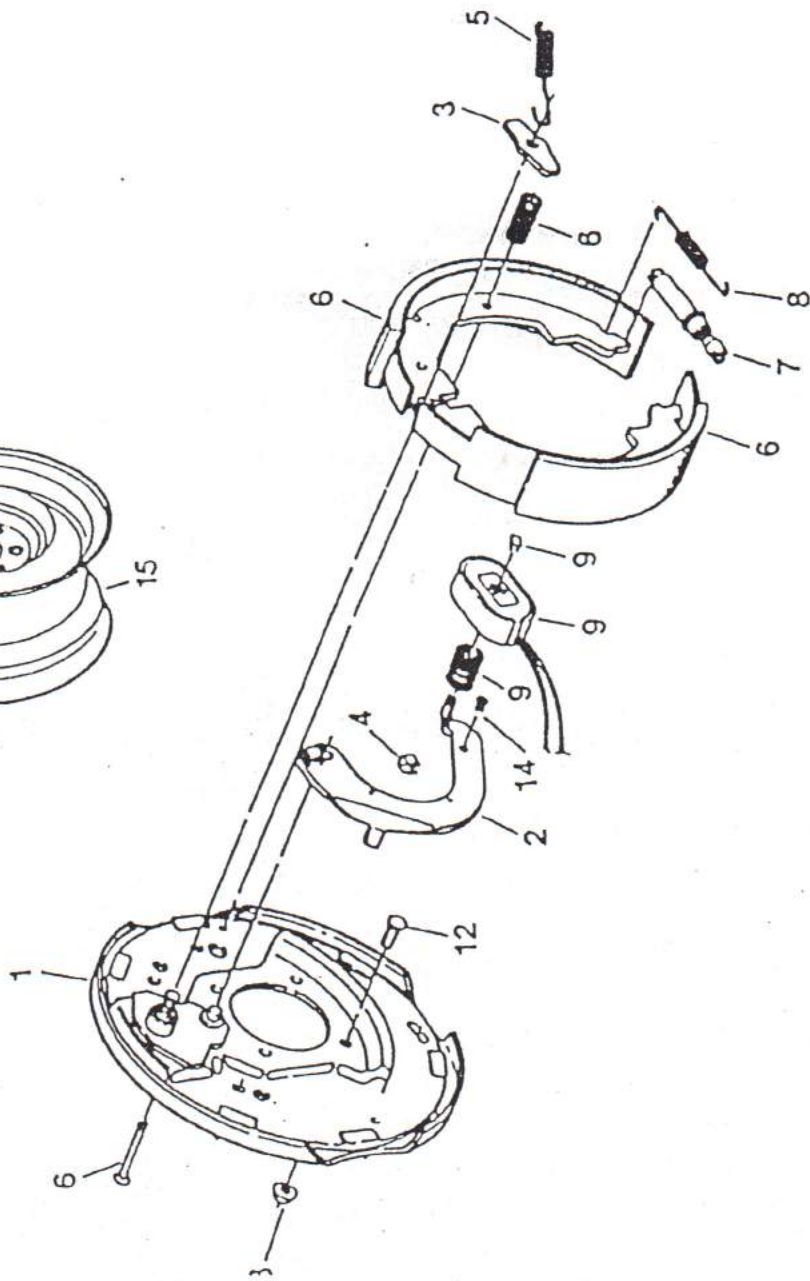
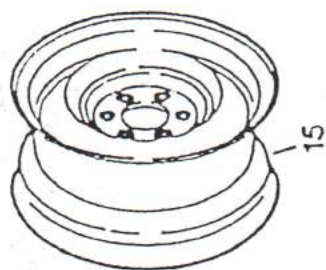
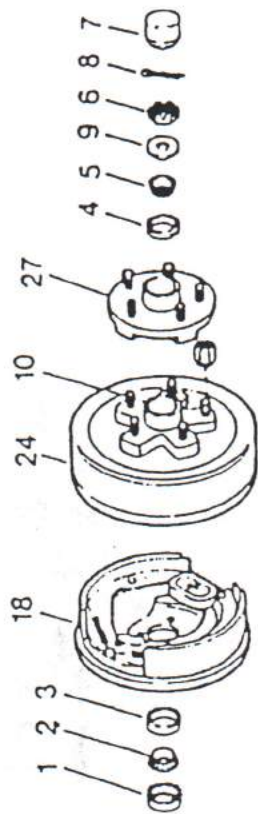

GROUP 05

HYDRAULIC SCHEMATIC
OPEN LOOP BALL VALVE

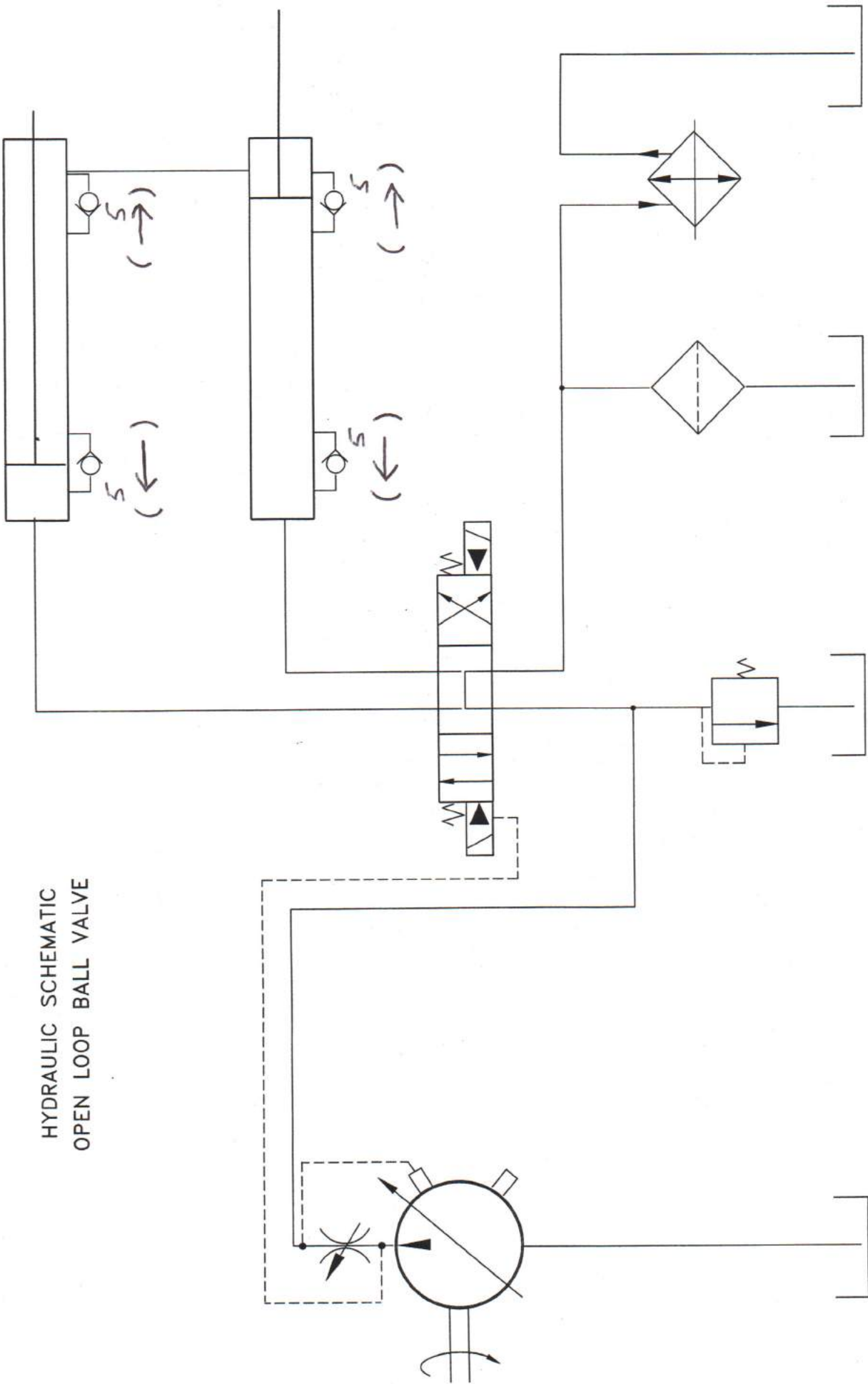

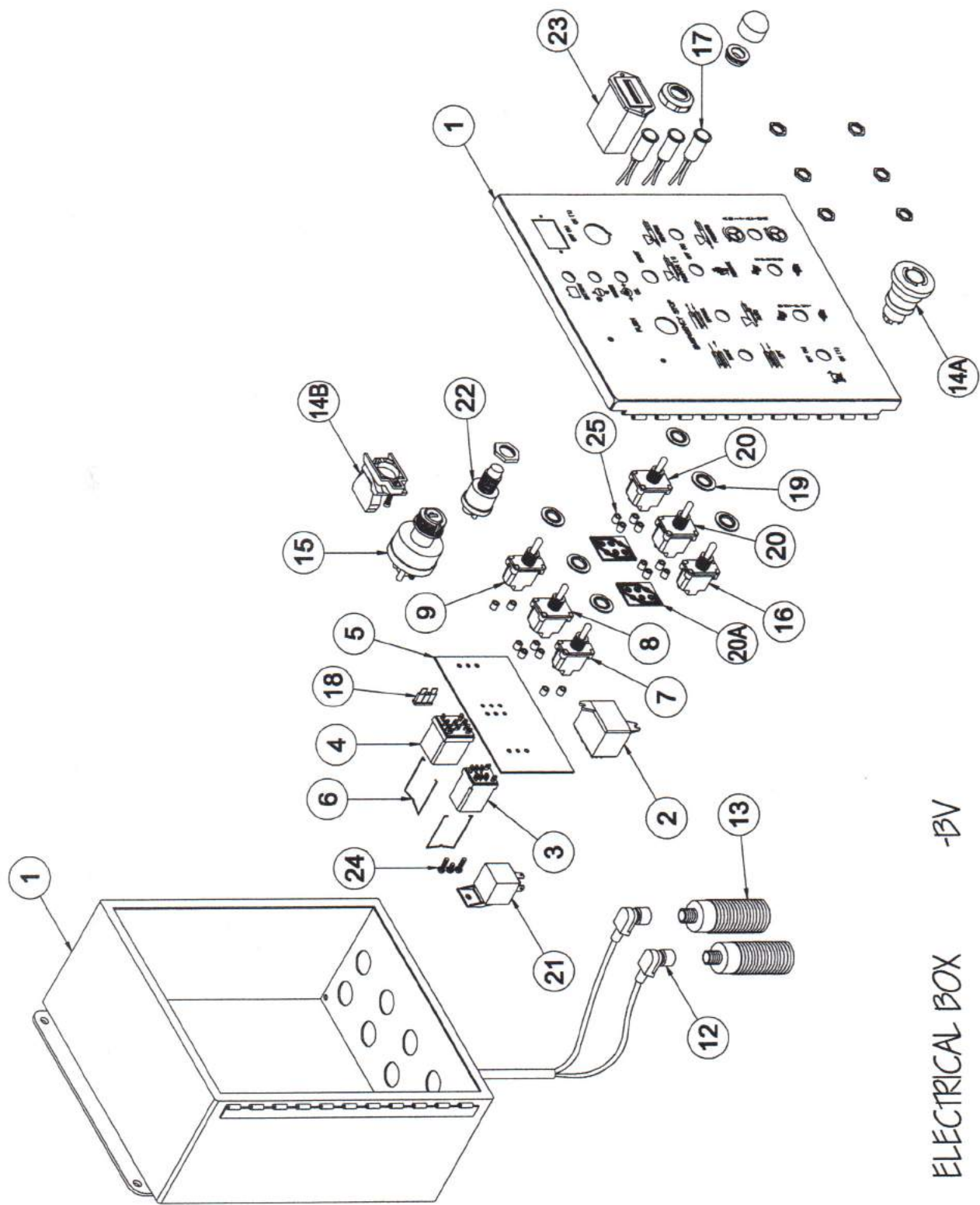

ELECTRICAL BOX -BV

PARTS LIST: MODELS

ALL BV EXCEPT 'CA'

GROUP 20

ITEM #	PART #	DESCRIPTION	# REQ	FOR MODEL (S)
1	15001	CONTROL BOX ONLY	1	ALL
1	15004	CONTROL BOX COMPLETE	1	ALL
2	15041	RELAY RH4	3	ALL
3	15045	RELAY RH2L CYCLING	1	ALL
4	15040	RELAY RH2 REMOTE	1	ALL EARLY
5	15036	CIRCUIT BOARD	1	ALL
6	15046	CLIP, RELAY	3	ALL
7	15020	SWITCH, STROKE	1	ALL
8	15025	SWITCH, AUTO/MANUAL	1	ALL
9	15030	SWITCH, PANEL/OFF/REMOTE	1	ALL
12	15101	CABLE, PROXIMITY SWITCH	2	ALL
12	15100	SWITCH, PROXIMITY	2	ALL
14	15395	E-STOP SWITCH COMPLETE	1	ALL
14A	15396	CONTACT, E-STOP	1	ALL
14B	15397	BUTTON, E-STOP	1	ALL
15	15005	SWITCH, KEY	1	ALL
16	15032	SWITCH, VIBRATOR	1	ALL
17	15010	LIGHT, RED	1	ALL
	15011	LIGHT, GREEN	1	ALL
	15012	LIGHT, BLUE	1	ALL
18	15039	FUSE, 20A, PLUG IN	1	ALL
19	15007	WASHER, SEALING	1/SWITCH	ALL
20	15262	SWITCH, OUTPUT	1	ALL
20	15262	SWITCH, OUTPUT	1	ALL
20A	15263	CIRCUIT BOARD, SWITCH	1/SWITCH	ALL
21	15398	RELAY, E-STOP	1	ALL
22	15006	SWITCH, PUSH BUTTON	1	ALL
23	15016	HOURLMETER	1	ALL
24	15402-1	SCREW, SWITCH, LONG		ALL
25	15402-2	SPACER, SWITCH SCREW		ALL
	15402	SCREW W/SPACER		ALL
	15400	BUSHING, CABLE, W/NUT (MEDIUM)		ALL
	15401	BUSHING, CABLE, W/NUT (LARGE)		ALL
	15403	PLUG, BLACK CLIP-IN (SMALL)		ALL
	15404	PLUG, BLACK CLIP-IN (MED)		ALL
	15405	PLUG, BLACK CLIP-IN (LARGE)		ALL
			0	

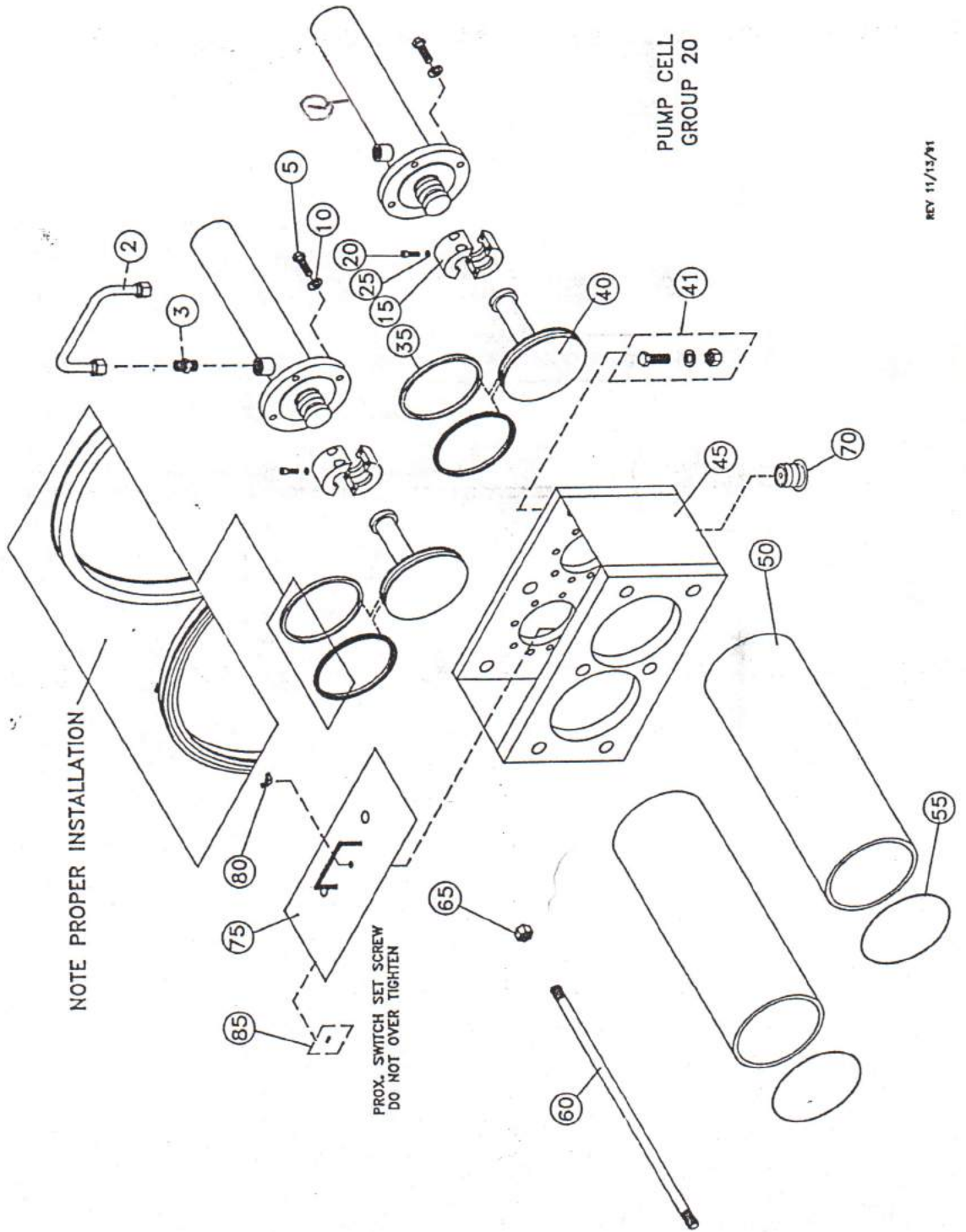

PARTS LIST, MODELS

5 40/5 45/5 50/5 65/5 85
5 110

ITEM #	PART #	DESCRIPTION	# REQ	FOR MODEL (S)
1	20003	HYD CYLINDER, 2.5 X 24	2	5 40/5 45/5 50
	20005	HYD CYLINDER, 3.5 X 24	2	5 65
	20006	HYD CYLINDER, 3.5 X 36	2	5 85
	20010	HYD CYLINDER, 3.5 X 54	2	5 110
2	70125	CYL LOOP HOSE	1	ALL
3	73720	STRAIGHT FITTING	2	ALL
5	20020	BOLT	8	ALL
15	20060	COUPLER CLAMP	2	ALL EXCEPT 5 110
	20060E	COUPLER CLAMP	2	5 110
20	20080	SHCS, CLAMP	8	ALL
25	20100	HIGH COLLER L/W	8	ALL
35	20120	POLY PAK, 5"	4	5 40/5 45
	20121	POLY PAK, 7"	4	5 65/5 85/5 110
	20123	POLY PAK, 6"	4	5 50
40	20140	PISTON, 5" WITH COUPLER	2	5 40/ 5 45
	20141	PISTON, 7"	2	5 65/5 85/5 110
	20143	PISTON, 6" WITH COUPLER	2	5 50
	20110	COUPLER	2	5 65/5 85/5 110
41	20160	BOLT, WASHER, NUT	2	ALL
45	20180-1	WASHBOX WELDMENT	1	ALL
50	20201	MAT'L CYL, 5 X 26	2	5 40/5 45
	20202	MAT'L CYL, 7 X 26	2	5 65
	20206	MAT'L CYL, 6 X 26	2	5 50
	20204	MAT'L CYL, 7 X 38	2	5 85
	20208	MAT'L CYL, 7 X 56	2	5 110
51	20207	ADAPTOR RING, 7 X 5, WITH O'RING	2	5 40/5 45
	20208-1	ADAPTOR RING, 7 X 6, WITH O'RING	2	5 50
55	20220	O'RING, CYL	2	5 40/5 45
	20222	O'RING, CYL	2	5 65/5 85/5 110
	20221	O'RING, CYL	2	5 50
60	20241	TIE ROD	6	5 40/5 45/5 50/5 65
	20242	TIE ROD	6	5 85
	20250	TIE ROD, GR 8	6	5 110
65	20260	NUT	6	ALL EXCEPT 5 110
	20350	NUT, FINE THD, GR 8	6	5 110
70	20280	DRAIN PLUG	1	ALL
75	20310	WASH BOX COVER	1	ALL EXCEPT 5 110
	20311	WASH BOX COVER	1	5 110
85	20370	SHCS, SENSOR	2	ALL

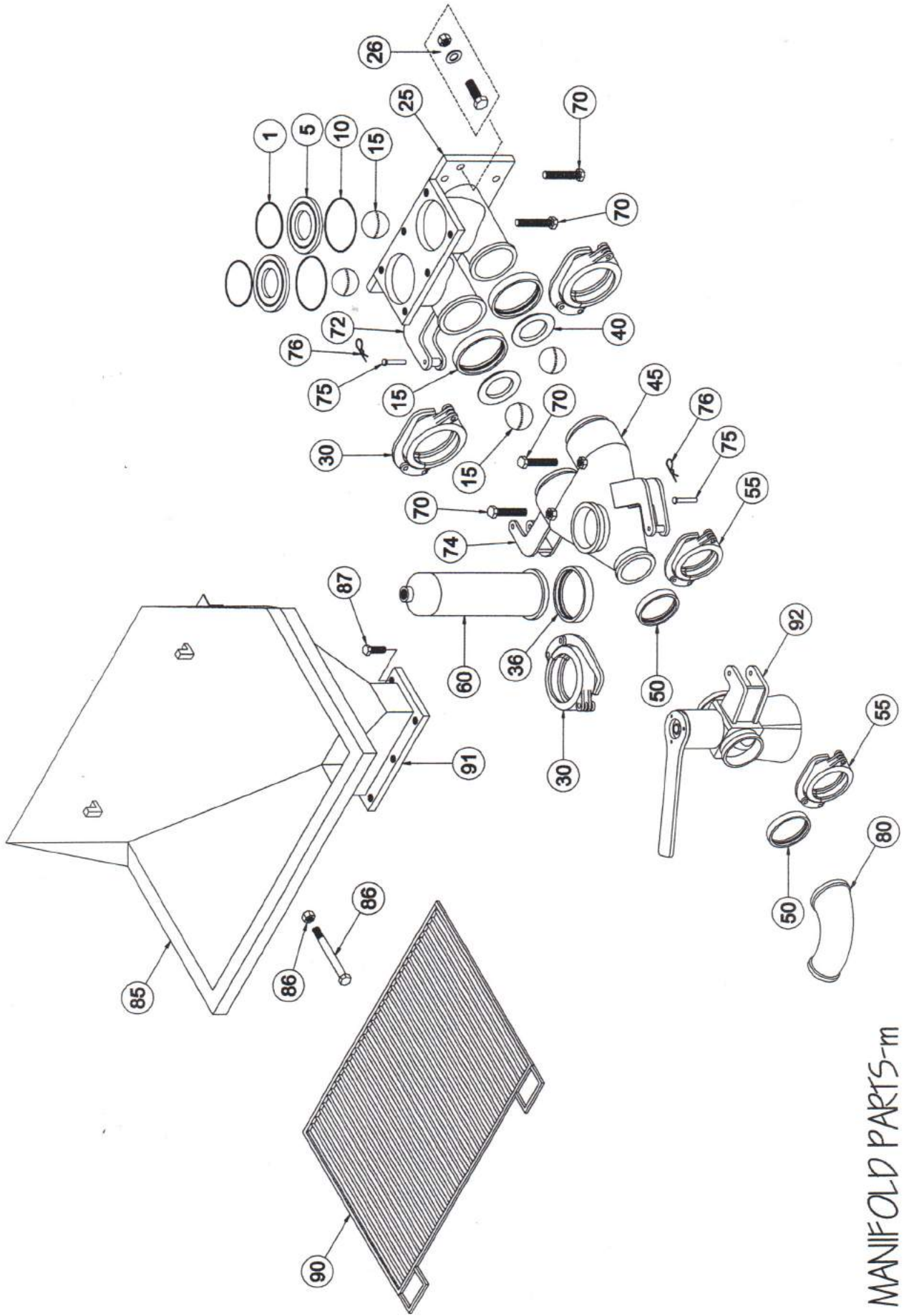

MANIFOLD PARTS-111

PARTS LIST: MODELS

ALL MILLENIUM

GROUP 15

ITEM #	PART #	DESCRIPTION	# REQ	FOR MODEL (S)
1	25001	SEAT O'RING, SMALL	2	ALL
5	25020	SEAT, INTAKE	2	5 25 THRU 5 50
5	25023	SEAT, INTAKE	2	5 65 THRU 5 170CAm
10	25040	SEAT O'RING, LARGE	2	ALL
15	25060	BALL, 4"	4	5 25 THRU 5 50
15	25061	BALL, 4-1/2"	2	5 65 THRU 5 170CAm
15	25060	BALL, 4"	2	5 65 THRU 5 170CAm
25	25100	MANIFOLD, INTAKE 5"	1	5 25 THRU 5 45
25	25099	MANIFOLD, INTAKE 6"	1	5 50
25	25101	MANIFOLD, INTAKE 7"	1	5 65, 5 85, 5 110
25	25102	MANIFOLD, INTAKE 8"	1	5 75 THRU 5 170CAm
26	25120	BOLT, WASHER & NUT	2	ALL
30	25140	COUPLING, 5"	2	ALL
30	25130	COUPLING, 6" OLIN	1	ALL
35	25160	GASKET, 5" FLANGED OLIN	2	ALL
36	25170	GASKET, HALF O'RING TYPE	1	ALL
40	25021	SEAT, DISCHARGE	2	ALL
45	25200	MANIFOLD, DISCHARGE 5" SURGE CH	1	5 25 THRU 5 45 EARLY
45	25200-1	MANIFOLD, DISCHARGE 6" SURGE CH	1	ALL
50	25220	GASKET, 4" HD	1	ALL
55	25240	COUPLING, 4" HD	1	ALL
60	25260	SURGE CHAMBER 5"	1	5 25 THRU 5 45 EARLY
60	25270	SURGE CHAMBER 6"	1	ALL
70	25080	STOP BOLT	4	ALL
72	25202-2	HINGE WELDMENT, INTAKE	1	ALL
74	25203	HINGE WELDMENT, DISCHARGE	1	ALL
75	25340	HINGE PIN	1	ALL
76	25340-1	CLIP, HINGE PIN	1	ALL
80	25360	DISCHARGE ELBOW, 4" X 3" HD	1	ALL
85	40001-2	HOPPER	1	5 25 THRU 5 110
85	40001	HOPPER, CA	1	5 75 THRU 5 170CAm
86	40120	HINGE BOLT & NUT	1	ALL
87	40100	BOLT, HOPPER	6	ALL
90	40020	SCREEN	1	5 25 THRU 5 110
90	40021	SCREEN, CA	1	5 75 THRU 5 170CAm
91	40001-1	BASE PLATE, HOPPER	1	ALL
92	81000	DEL SYS PRESSURE RELEASE VALVE	1	ALL
			0	

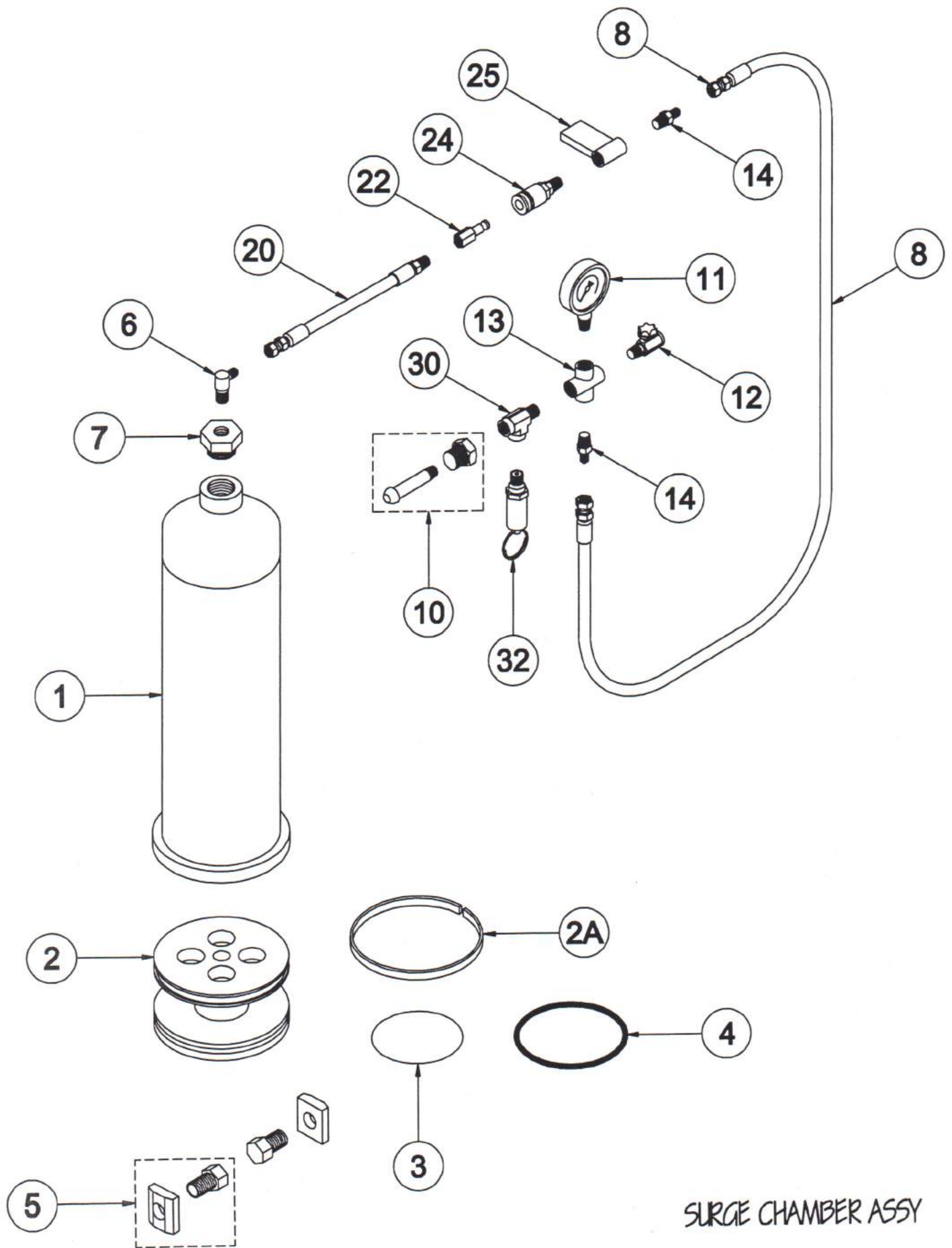

SURGE CHAMBER ASSY

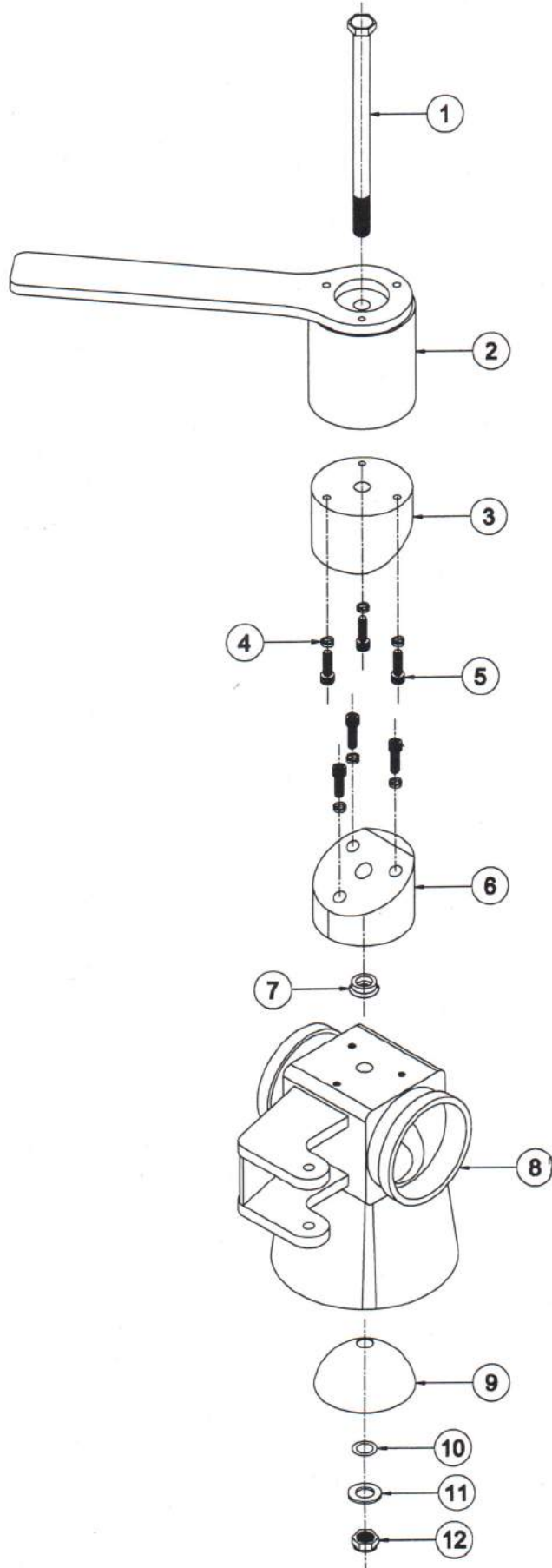

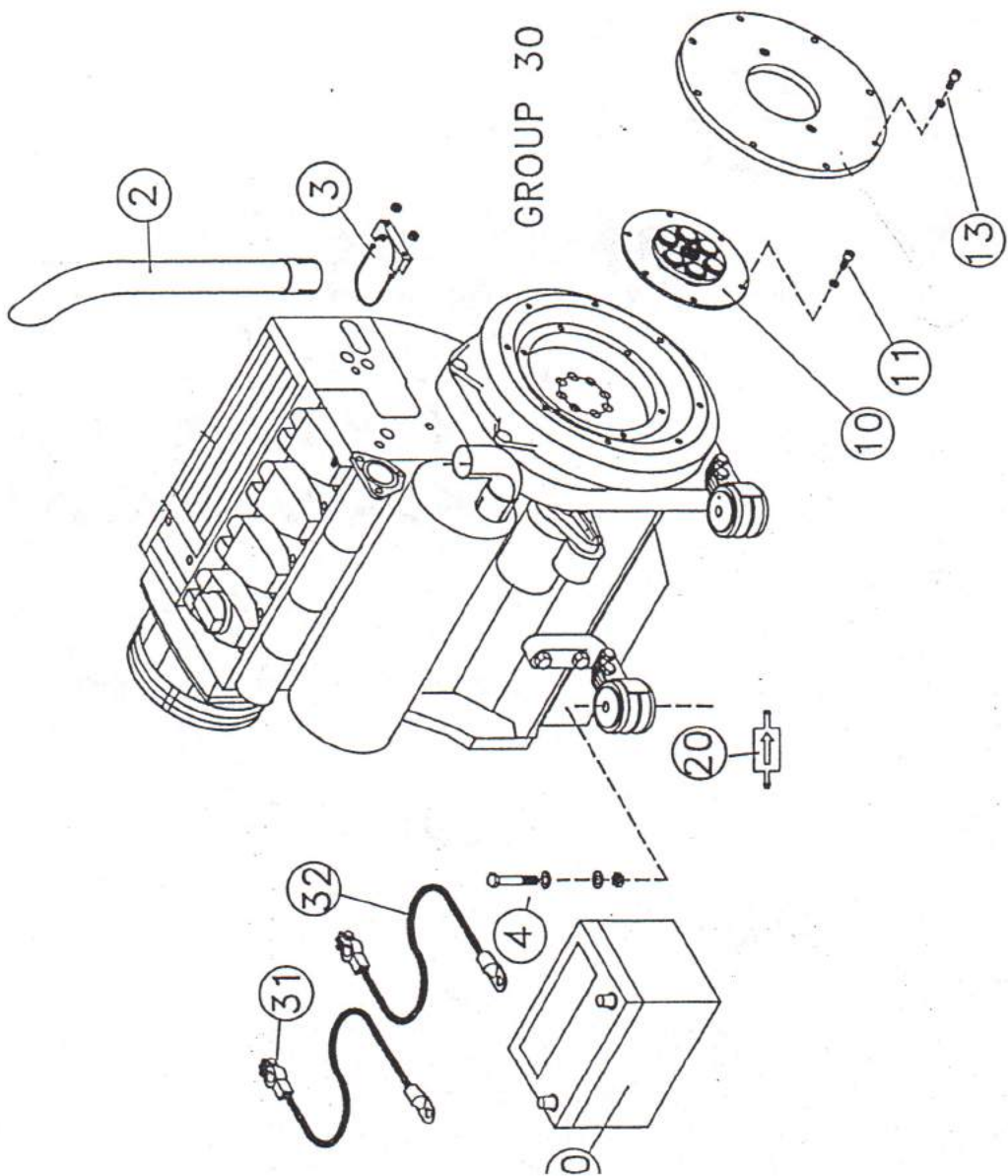

ITEM #	PART #	DESCRIPTION	# REQ	FOR MODEL (S)
	30261	ENGINE	1	5 40
	30262	ENGINE	1	5 45
	30263	ENGINE	1	5 65
	30265	ENGINE	1	5 85
2	30040	TAIL PIPE (CHROME)	1	5 40
3	30070	U CLAMP 2"	1	5 40
	30060	MUFFLER ASSEMBLY	1	5 45
	30061	MUFFLER MOUNTING BRACKET	2	5 45
	30053	MUFFLER ASSEMBLY	1	5 65/5 85
	30065-2	MUFFLER MOUNTING BRACKET	2	5 65/5 85
	30049	HEAT SHIELD COMPLETE WITH MOUNTING BRACKETS	1	5 65/5 85
4	30100	BOLT, WASHER & NUT	4	ALL MODELS
	30191	THROTTLE CABLE	1	ALL MODELS
	30192	CABLE PIVOT	1	ALL MODELS
	30196	CABLE HUB KIT	1	ALL MODELS
	30193	THROTTLE ARM	1	5 40.5 45
	30194	THROTTLE ARM	1	5 65/5 85
	30198	LINEAR THROTTLE ACTUATOR	1	5 40/5 45 WHEN INSTALLED
	30199	LINEAR THROTTLE ACTUATOR	1	5 65/5 85 WHEN INSTALLED
	30198-1	THROTTLE ARM FOR LINEAR ACTUATOR	1	5 40/5 45 WHEN INSTALLED
	30198-1A	THROTTLE ARM FOR LINEAR ACTUATOR	1	5 65/5 85 WHEN INSTALLED
	30198-2	PIVOT MOUNT FOR LINEAR ACTUATOR	1	5 40/5 45 WHEN INSTALLED
	30198-3	MOUNT FOR LINEAR ACTUATOR	1	5 65/5 85 WHEN INSTALLED
10	30200-1	PUMP DRIVE/MOUNT ASSEMBLY	1	5 40/5 45
	30202	PUMP DRIVE/MOUNT ASSEMBLY	1	5 65/5 85
11	30280	BOLT & WASHER	8	ALL MODELS
13	30340	BOLT & WASHER	8	ALL MODELS
20	30011	FUEL FILTER, ELEMENT	1	5 40/5 45
	30012	FUEL FILTER, ELEMENT	1	5 65/5 85
30	30671	BATTERY	1	ALL MODELS
31	30700	POSITIVE CABLE	1	ALL MODELS
32	30730	NEGATIVE CABLE	1	ALL MODELS
	30770	BATTERY HOLD-DOWN	1	ALL MODELS
	30084	AIR CLEANER	1	5 65/5 85
	30084-1	AIR CLEANER ELEMENT	1	5 65/5 85
	30085	HUMP HOSE	1	5 65/5 85
	30086	REDUCER	1	5 65/5 85
	30081-10	MOUNTING BRACKET WELDMENT	1	5 65/5 85

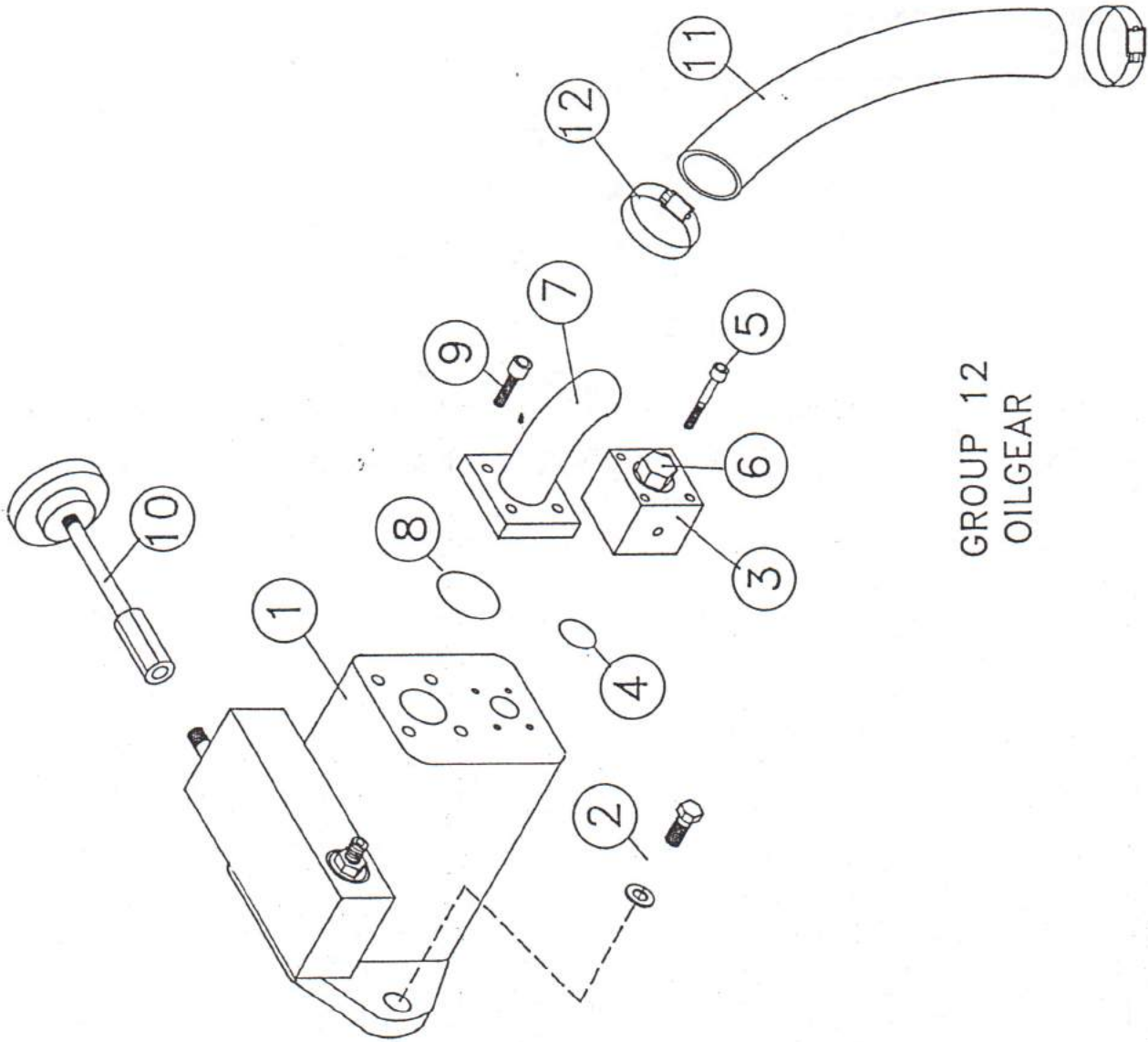

GROUP 12
OILGEAR

RELAY - RH4B-UT

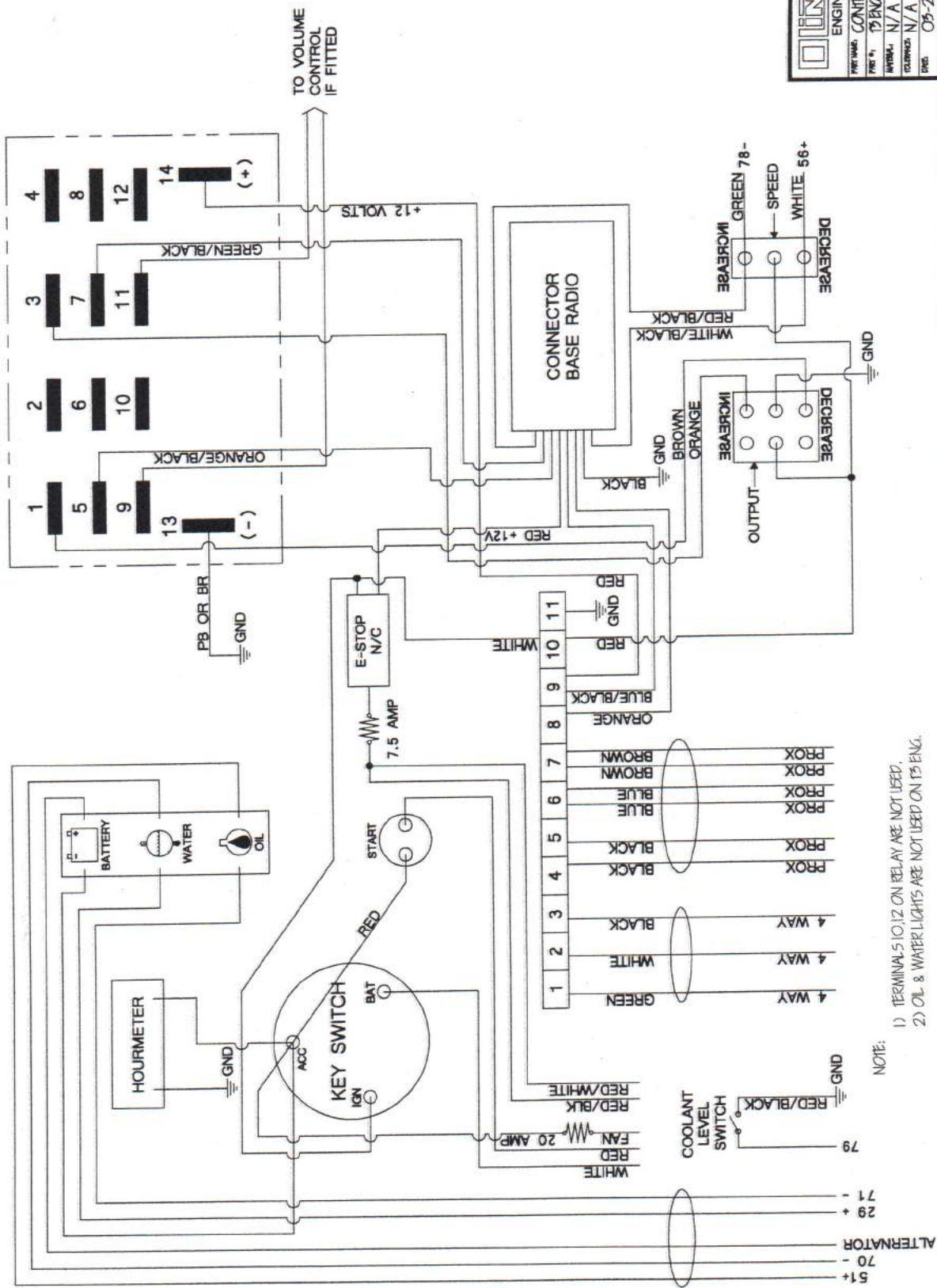

NOTE:
1) TERMINALS 5, 10, 12 ON RELAY ARE NOT USED.
2) OIL & WATER LIGHTS ARE NOT USED ON 15 ENG.

*THE FOLLOWING PAGE CONTAINS
A LIST OF THE STANDARDIZED
SAFETY LABELS POSTED ON YOUR
PUMP AT THE TIME OF MANUFACTURE
OR REFURBISHMENT.
USE IT TO ORDER REPLACEMENTS
FROM OLINPUMP
OR
YOUR OLIN DEALER.*

010 **WARNING**
Buckle up. Never use a motor or battery crank for dismount.
ADVERTENCIA
Nunca use el motor o batería para bajar. Siempre use el manual de operación.

014 **WARNING**
Before opening a battery cap, release pressure by releasing pump pressure.
ADVERTENCIA
Antes de presionar sobre un detector para liberar la presión, libérela primero de la bomba. Véase el manual.

018 **WARNING**
Use retaining pins in all delivery system snap clamps.
ADVERTENCIA
Use pin retenedores de seguridad en todas las abrazaderas de presión para sistemas de entrega.

022 **IMPORTANT** **IMPORTANT**
See below

027
see below

028 **WARNING**
Do not use the boom as a crane or hoist.
ADVERTENCIA
No usar la pluma como grúa o aparato de levante.

032 **EXTEND OUTRIGGER TO HERE BEFORE UNFOLDING BOOM**
EXTIENDA EL ESTABILIZADOR HASTA AQUÍ ANTES DE DESPLEGAR LA PLUMA

033 **INSTRUCCIONES DE SEGURIDAD** **SAFETY INSTRUCTIONS**
* For reference only. Each manufacturer to make a similar decal applicable to their models and features.

042

011 **WARNING**
Flying hoist, ladder, etc. may extend beyond safety limits.
ADVERTENCIA
El cable, el andamio, etc. puede extenderse más allá de los límites de seguridad.

015 **WARNING**
Do not touch the motor without wearing the warning or safety glasses.
ADVERTENCIA
No tocar el motor sin usar gafas de seguridad o gafas de protección.

019 **WARNING**
Crushing hazard. Clear area when activating equipment.
ADVERTENCIA
Peligro de aplastamiento. Despejar el área antes de activar los estabilizadores.

023 **WARNING**
Step off hoist pins.
ADVERTENCIA
Desplácese de los pines de los estabilizadores.

024 **WARNING**
Safety guard is missing.
ADVERTENCIA
Guarda de seguridad está faltando.

029 **WARNING**
Do not use the boom as a crane or hoist.
ADVERTENCIA
No usar la pluma como grúa o aparato de levante.

034 **WARNING**
This machine is remote controlled and may start at any time. Stop engine before servicing unit.
ADVERTENCIA
Esta máquina funciona a control remoto y puede ponerse en marcha en cualquier momento. Apague el motor antes de realizar el mantenimiento.

036 **DANGER**
Electrocution hazard. Stay back from power lines at least 17 feet (5 meters).
PELIGRO
Riesgo de electrocución. Manténgase por lo menos a una distancia de 5 metros (17 pies) de los cables de energía.

038

040

012 **WARNING**
Keep feet off end of outrigger. Keep hands off outrigger. Keep inside in place.
ADVERTENCIA
No poner los pies en el extremo de la grúa. Manténgase alejado de la grúa. Manténgase en su posición correcta.

016 **ADVERTENCIA** **WARNING**

020 **WARNING**
Do not touch the motor without wearing the warning or safety glasses.
ADVERTENCIA
No tocar el motor sin usar gafas de seguridad o gafas de protección.

025 **WARNING**
Do not touch the motor without wearing the warning or safety glasses.
ADVERTENCIA
No tocar el motor sin usar gafas de seguridad o gafas de protección.

030 **WARNING**
Do not touch the motor without wearing the warning or safety glasses.
ADVERTENCIA
No tocar el motor sin usar gafas de seguridad o gafas de protección.

031 **DANGER**
Stay clear. Contact will result in death or serious injury if the unit becomes electrically charged.
PELIGRO
Manténgase alejado. Peligro de muerte o lesiones serias si se toca cuando la unidad está cargada eléctricamente.

035 **WARNING**
Do not touch the motor without wearing the warning or safety glasses.
ADVERTENCIA
No tocar el motor sin usar gafas de seguridad o gafas de protección.

037

0041

013 **WARNING**
Do not touch the motor without wearing the warning or safety glasses.
ADVERTENCIA
No tocar el motor sin usar gafas de seguridad o gafas de protección.

017 **WARNING**
Do not touch the motor without wearing the warning or safety glasses.
ADVERTENCIA
No tocar el motor sin usar gafas de seguridad o gafas de protección.

021 **WARNING**
Do not touch the motor without wearing the warning or safety glasses.
ADVERTENCIA
No tocar el motor sin usar gafas de seguridad o gafas de protección.

026 **WARNING**
Do not touch the motor without wearing the warning or safety glasses.
ADVERTENCIA
No tocar el motor sin usar gafas de seguridad o gafas de protección.

033 **INSTRUCCIONES DE SEGURIDAD** **SAFETY INSTRUCTIONS**
* For reference only. Each manufacturer to make a similar decal applicable to their models and features.

039
see below

041

FIG. 8 Standardized safety labels

STABILITY CALCULATION FOR OLIN TRAILER MOUNTED PUMPS

BECAUSE WEIGHTS AND DIMENSIONS VARY BETWEEN DIFFERENT MODELS AND MODEL YEARS AND DUE TO AVAILABLE OPTIONS AND CUSTOMER MODIFICATIONS, THE FOLLOWING FORMULA WILL ALLOW YOU TO CALCULATE YOUR MACHINE'S CENTER OF GRAVITY. A TRUCK WHEEL SCALE OR FREIGHT SCALE AND A MEASURING DEVICE WILL BE NECESSARY.

THIS WORKS ON SINGLE OR TANDEM AXLE UNITS.

- 1. WEIGH EACH TIRE OF EACH AXLE, ONE AT A TIME, TO FIND THE TOTAL WEIGHT ON EACH AXLE.**
- 2. MEASURE FORWARD FROM THE CENTER OF EACH SPINDLE OF EACH AXLE TO THE FORWARDMOST POINT OF THE PUMP.**
- 3. WEIGH THE JACK STAND ON THE TONGUE OF THE PUMP, AND MEASURE THE DISTANCE OF IT'S CENTER TO THE SAME POINT AT THE FRONT.**
- 4. MULTIPLY THE WEIGHT OF EACH AXLE BY IT'S CORRESPONDING DISTANCE FROM THE POINT UP FRONT. WE'LL CALL THIS TOTAL M1 FOR A SINGLE OR REAR AXLE, AND M2 FOR THE SECOND AXLE IF EQUIPPED.**
- 5. MULTIPLY THE JACK'S WEIGHT BY IT'S RELATIVE DISTANCE. WE'LL CALL THIS TOTAL M3.**
- 6. ADD THESE 2 OR 3 TOTALS TOGETHER (M1+M2+M3), AND DIVIDE THAT TOTAL BY THE WEIGHT OF THE PUMP ITSELF (AXLE WEIGHT PLUS JACK WEIGHT). THE RESULTING NUMBER IS THE CENTER OF GRAVITY (MASS) IN WHATEVER UNIT OF MEASURE YOU USED, FROM THE POINT AT THE FRONT OF THE PUMP.**

EXAMPLE:

MODEL 5 45

WEIGHT ON AXLE=3930 LBS, DISTANCE=100"

WEIGHT ON JACKSTAND=230 LBS, DISTANCE=22"

$$\mathbf{M1=3930 \times 100=393,000}$$

$$\mathbf{M3=230 \times 22=5,060}$$

$$\mathbf{M1+M3=398,060}$$

3930+230=4,160, TOTAL PUMP WEIGHT

$$\mathbf{398,060/4,160=95.7}$$

**THE CTR OF GRAVITY IS 95.7" BACK FROM THE POINT AT
THE FRONT OF THE PUMP.**